

# CLICK assembly

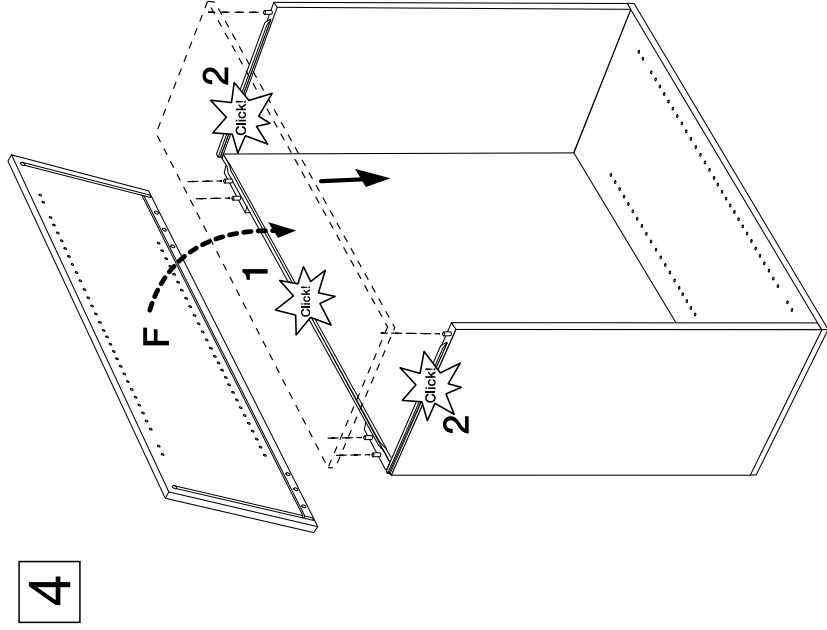

# CLICK disassembly

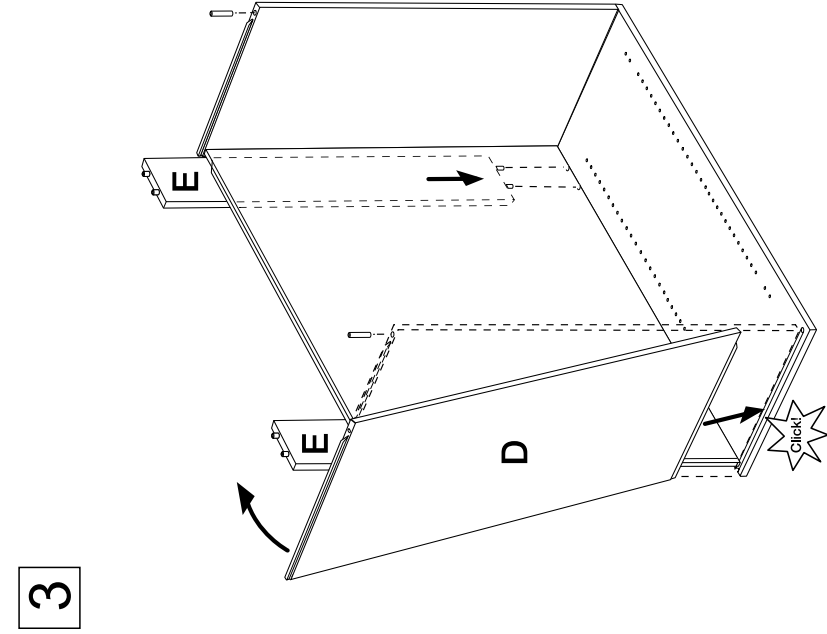
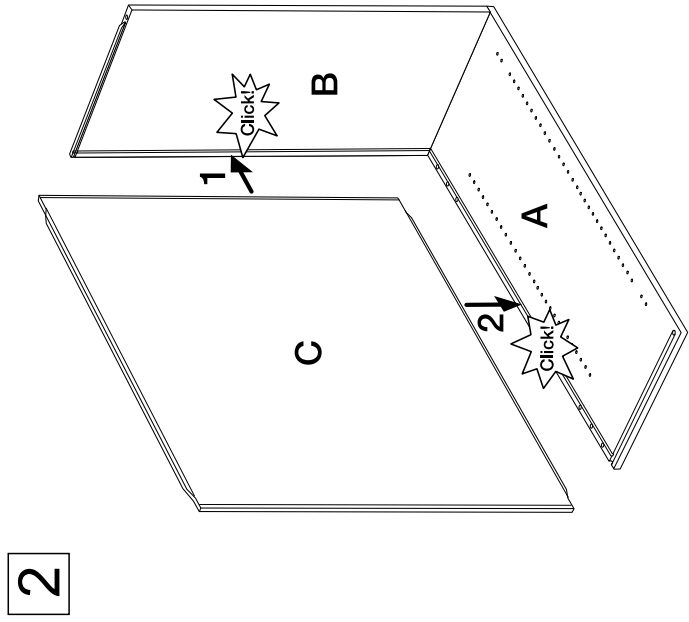
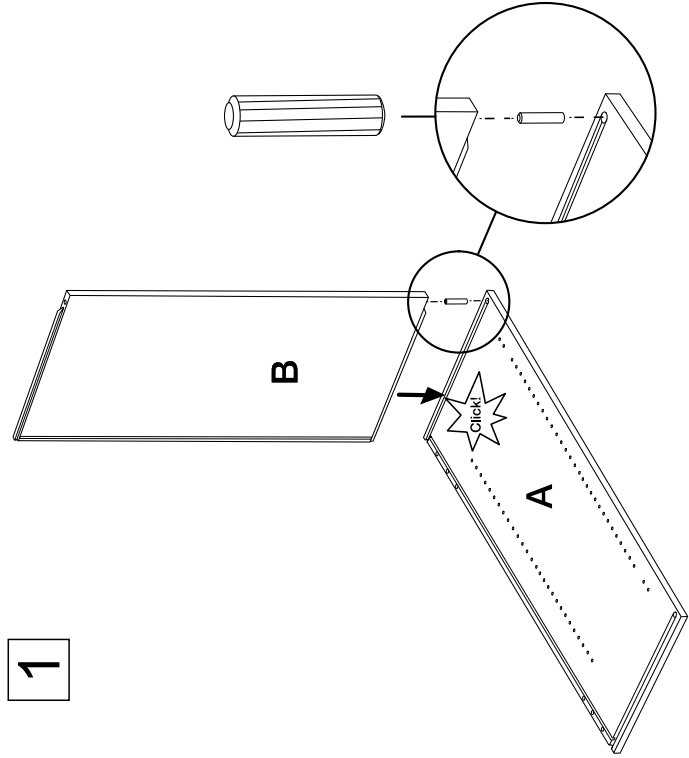
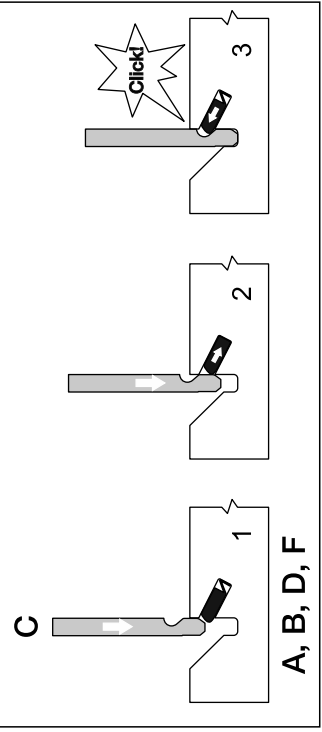
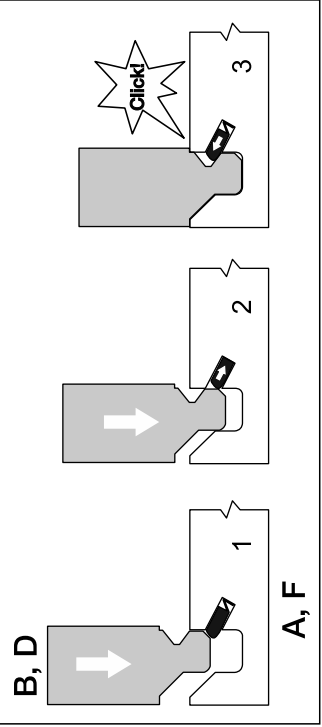

1

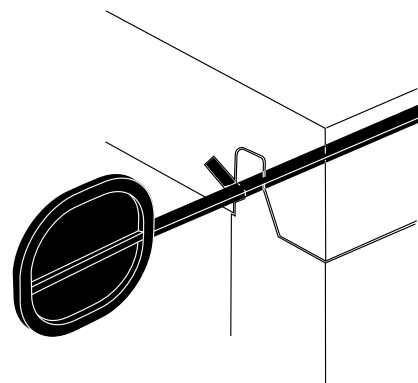
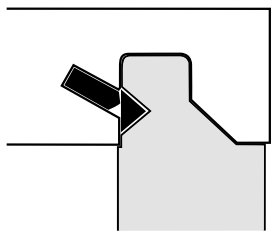
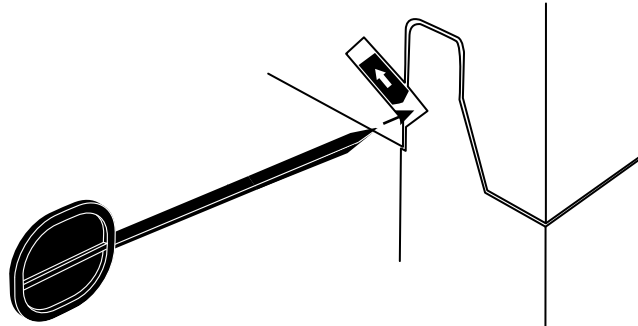
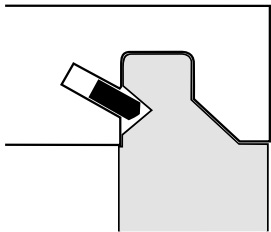
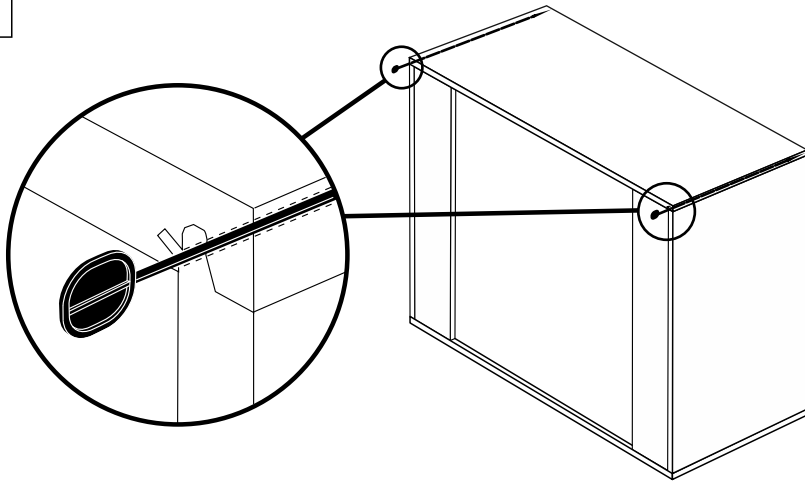

2

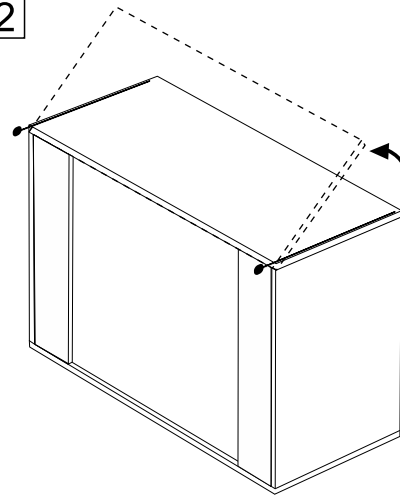

3

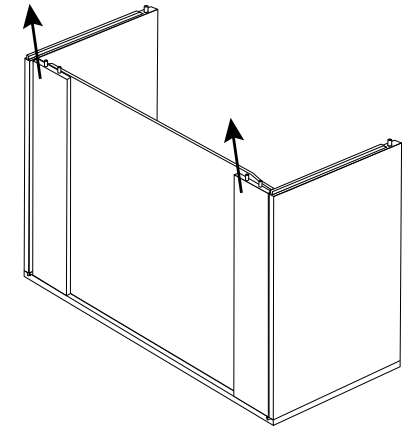

4

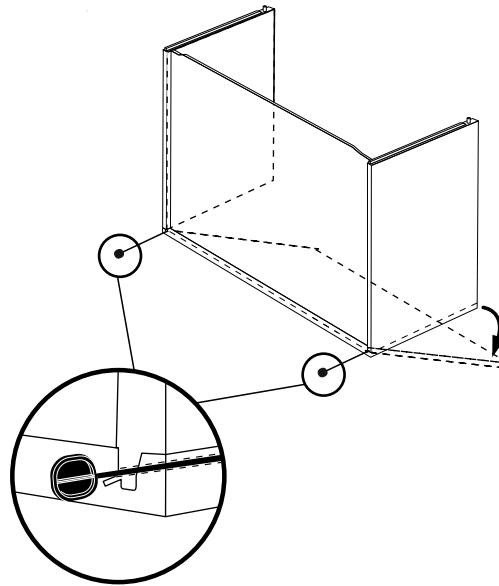

5

